

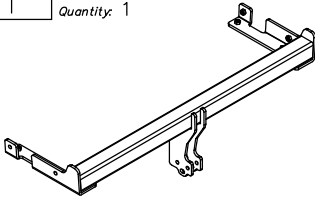





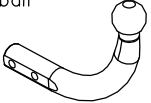
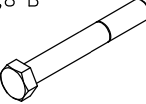

## Towbar accessories:

Pos. 1	Name: Main bar Quantity: 1	Pos. 4	Name: Ball cover Quantity: 1	Pos. 8	Name: Washer Quantity: 4 Dim. : $\varnothing 42 \times \varnothing 13 \times 3 \text{mm}$
					
					
					
					

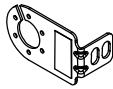

## PPUH AUTO-HAK Sp.J.

Produkcja Zaczepów Kulowych  
Henryk & Zbigniew Nejman  
76-200 SŁUPSK ul. Słoneczna 16K  
tel/fax (059) 8-414-414; 8-414-413  
E-mail: [office@autohak.com.pl](mailto:office@autohak.com.pl)  
[www.autohak.com.pl](http://www.autohak.com.pl)

### Towing hitch (without electrical set)

Class: **A50-X** Cat. no. **Z12**

Designed for:

Manufacturer: **mitsubishi**

Model: **GALANT**

Type: **4/5 doors (E5)**

produced since 11.1992 till 08.1996

Type: **4/5 doors (EA, 2/5/6W)**

produced since 09.1996 till 10.2004

Technical data:

**D-value: 9,02 kN**

maximum trailer weight: **1800 kg**

maximum vertical cup load: **75 kg**

Approval number acc. to regulations EKG/ONZ 55.01: **E20-55R-01 1333**

### Foreword

This towbar is designed according to rules of safety traffic regulations. The towing hitch is a safety component and can be install only by qualified personnel. Any alteration or conversion of the towing hitch is prohibited and would lead to cancellation of design certification. Remove insulating compound and underseal from vehicle (if present) in the area of the matting surfaces of the towing hitch.

The vehicle manufacturer's specifications regarding trailer load and max. vertical cup load are decisive for driving whereat values for the towing hitch cannot be exceeded.

*D-value formula:*

$$\frac{\text{Max trailer weight [kg]} \times \text{Max vehicle weight [kg]}}{\text{Max trailer weight [kg]} + \text{Max vehicle weight [kg]}} \times \frac{9,81}{1000} = D \text{ [kN]}$$

## FITTING INSTRUCTION

Clamp mark in acc. with		Cables joining
ISO	PN	
1	L	Left directional lights
2	+	Rear fog lights
3	31	Ground
4	R	Right directional lights
5	58R	Right side parking lights
6	54	Stoplights
7	58L	Left side parking lights

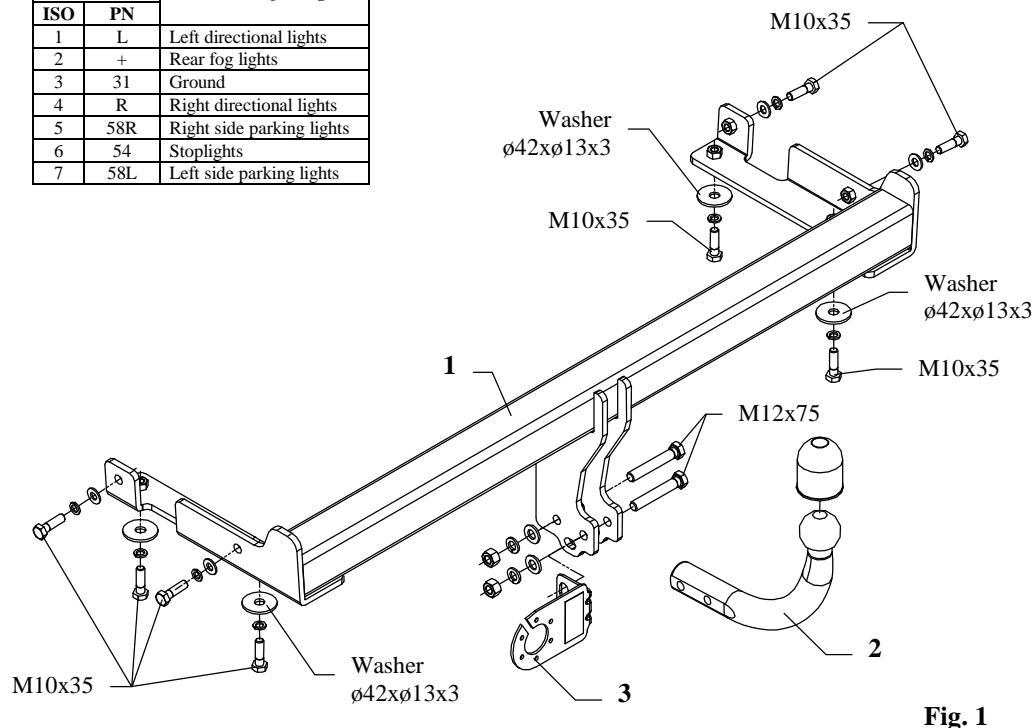

Fig. 1

This towbar is designed to assembly in following cars: **MITSUBISHI GALANT 4/5 doors (E5)**, produced since 11.1992 till 08.1996 and **MITSUBISHI GALANT 4/5 doors (EA, 2/5/6W)**, produced since 09.1996 till 10.2004, catalogue number **Z12** and is prepared to tow trailers max total weight **1800 kg** and max vertical load **75 kg**.

### From manufacturer

Thank you for buying our product. Their reliability has been confirmed in many tests. Reliability of towbar depends also on correct assembly and right operation. For this reasons we kindly ask to read carefully this instruction and apply to hints.

*The towbar should be install in points described by a car producer.*

## The instruction of the assembly

1. If necessary, remove the underseal from around the fitting points of the frame members.
2. Dismount the bumper and the protection shield.
3. Cut out fragment of the bumper as shown on the fig. 2.

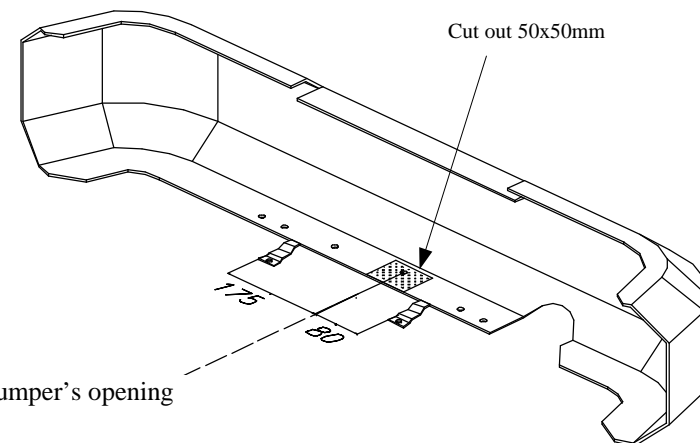

Fig. 2 Bumper's opening

4. If necessary, open the ends of the frame members by removing the end-plates from the rear panel. Slip main bar of the towbar (pos. 1) to the frame members in this way, so holes in the towbar tally with holes in the frame.
5. Fix the towbar to frame members using bolts M10x35mm (pos. 6) – see fig. 1.
6. Reassemble the bumper.
7. Fix tow-ball (pos. 2) and socket plate (pos. 3) using bolts M12x75mm (pos. 5) from accessories.
8. Tighten all bolts according to the torque shown in the table.
9. Connect electric wires of 7-bolts socket according to the instruction of the car. (Recommend to make at authorized service station)
10. Complete paint layer damaged during installation.

Torque settings for nuts and bolts (8,8):

<b>M6</b> - 11 Nm	<b>M8</b> - 25 Nm	<b>M10</b> - 50 Nm
<b>M12</b> - 87 Nm	<b>M14</b> - 138 Nm	<b>M16</b> - 210 Nm

### NOTE

After install the towbar you should get adequate note in registration book (at authorised service station).The car should be equipped with:

- Indicators
- Tow mirrors

After 1000km of exploitation check all bolts and nuts. The ball of towbar must be always kept clear and conserve with a grease.