

FITTING INSTRUCTION

Clamp mark in acc. with		Cables joining
ISO	PN	
1	L	Left directional lights
2	+	Rear fog lights
3	31	Ground
4	R	Right directional lights
5	58R	Right side parking lights
6	54	Stoptlights
7	58L	Left side parking lights

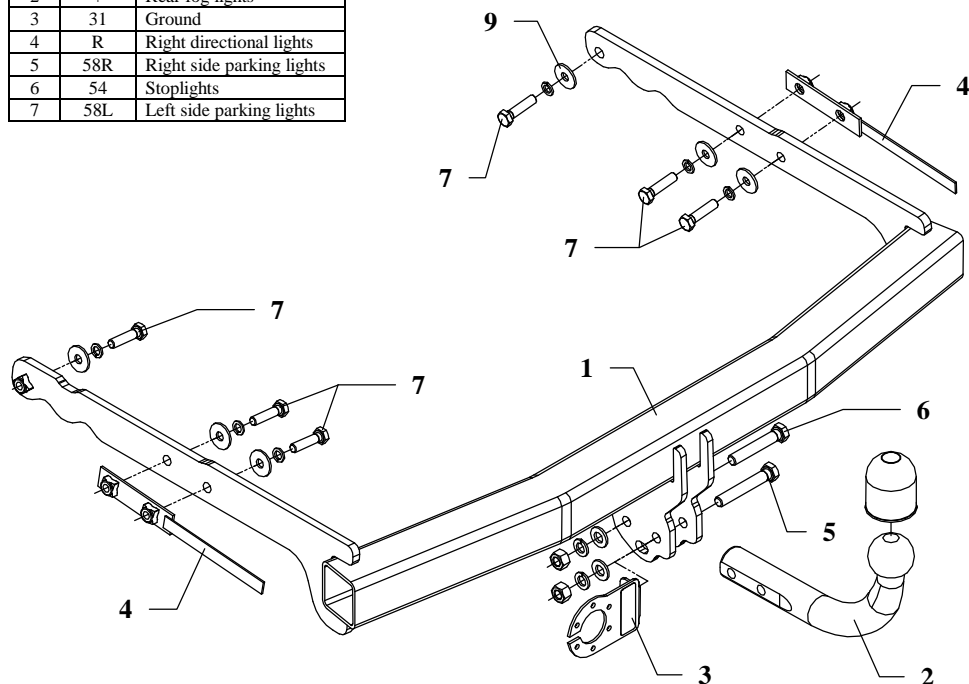

Fig. 1

This towing hitch is designed to assembly in following cars: **FORD MONDEO, 4 doors** and **ESTATE**, produced since 03.2007, catalogue no. **C50** and is prepared to tow trailers max total weight **2120 kg** and max vertical mass **80 kg**.

From manufacturer

Thank you for buying our product. Their reliability has been confirmed in many tests. Reliability of towing hitch depends also on correct assembly and right operation. For this reasons we kindly ask to read carefully this instruction and apply to hints.

The towing hitch should be install in points described by a car producer.

The instruction of the assembly

1. Remove the bumper and the steel buffer from the car. The buffer beam will no longer be needed. Fix again bolts fastening steel buffer beam.
2. Release the exhaust from the rearmost exhaust rubber and remove the heat shield.
3. **Attention!** For the saloon model with PDC the following applies: move the connector ca 10mm lower.
4. Slip the main bar of the towing hitch (pos. 1) to chassis members of the car in that way so holes of the towing hitch be covered with factory-made holes in chassis members.
5. Fix towing hitch using bolts M10x40mm (pos. 7). Use washers (pos. 9) and jibs with nuts (pos. 4).
6. **Attention!** The following only applies to the estate: cut out the fragment of the middle of the underside of the bumper as shown in fig. 2.
7. Install the bumper using original bolts.
8. Fix tow ball (pos. 2) using bolt M12x75mm (pos. 5) and M12x70mm (pos. 6). With bolt M12x75mm fix also a socket plate (pos. 3). See figure 1.
9. Tighten all bolts according to the torque shown in the table.
10. Connect electric wires of 7-poles socket according to the instruction of the car. (Recommend to make at authorized service station).
11. Complete paint layer damaged during installation.

Fig. 2

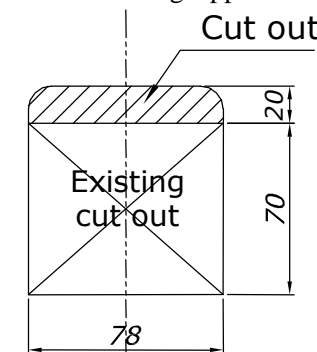

Torque settings for nuts and bolts (8,8):	
M 8 - 25 Nm	M 10 - 55 Nm
M 12 - 85 Nm	M 14 - 135 Nm

NOTE

After install the towing hitch you should get adequate note in registration book (at authorised service station). The car should be equipped with:

- Indicators
- Tow mirrors

After 1000km check all bolts and nuts. The ball of towing hitch must be always kept clear and conserve with a grease.

Towing hitch accessories:

Pos. 1 Main bar PCS.: 1	Pos. 5 Bolt 8,8 B M12x75mm PCS.: 1	Pos. 10 Plain washer Ø12mm PCS.: 2
	Pos. 6 Bolt 8,8 B M12x70mm PCS.: 1	Pos. 11 Spring washer Ø12mm PCS.: 2
Pos. 2 Tow ball PCS.: 1	Pos. 7 Bolt 8,8 B M10x40mm PCS.: 6	Pos. 12 Spring washer Ø10mm PCS.: 6
Pos. 3 Socket plate PCS.: 1	Pos. 8 Nut 8 B M12 PCS.: 2	Pos. 13 Ball cover PCS.: 1
Pos. 4 Jib PCS.: 2	Pos. 9 Washer Ø30xØ10.5x2.5mm PCS.: 6	



PPUH AUTO-HAK S.J.

Produkcja Zaczepów Kulowych
Henryk & Zbigniew Nejman
76-200 SŁUPSK ul. Słoneczna 16K
tel/fax (059) 8-414-414; 8-414-413
E-mail: office@autohak.com.pl
www.autohak.com.pl

Towing hitch (without electrical set)

Class: **A50-X** Cat. no. **C50**

Designed for:

Manufacturer: **FORD**

Model: **MONDEO**

Type: **4 doors, ESTATE**

produced since 03.2007

Technical data:

D-value: 11,6 kN

maximum trailer weight: **2120 kg**

maximum vertical cup mass: **80 kg**

Approval number according to Directive 94/20/EC: e20*94/20*0417*00

Foreword

This towing hitch is designed according to rules of safety traffic regulations. The towing hitch is a safety component and can be install only by qualified personnel. Any alteration or conversion of the towing hitch is prohibited and would lead to cancellation of design certification. Remove insulating compound and underseal from vehicle (if present) in the area of the matting surfaces of the towing hitch. The vehicle manufacturer's specifications regarding trailer mass and max. vertical cup mass are decisive for driving whereat values for the towing hitch cannot be exceeded.

D-value formula:

$$\frac{\text{Max trailer weight [kg]} \times \text{Max vehicle weight [kg]}}{\text{Max trailer weight [kg]} + \text{Max vehicle weight [kg]}} \times \frac{9,81}{1000} = D \text{ [kN]}$$