

FITTING INSTRUCTION

Clamp mark in acc. with		Cables joining
ISO	PN	
1	L	Left directional lights
2	+	Rear fog lights
3	31	Ground
4	R	Right directional lights
5	58R	Right side parking lights
6	54	Stoplights
7	58L	Left side parking lights

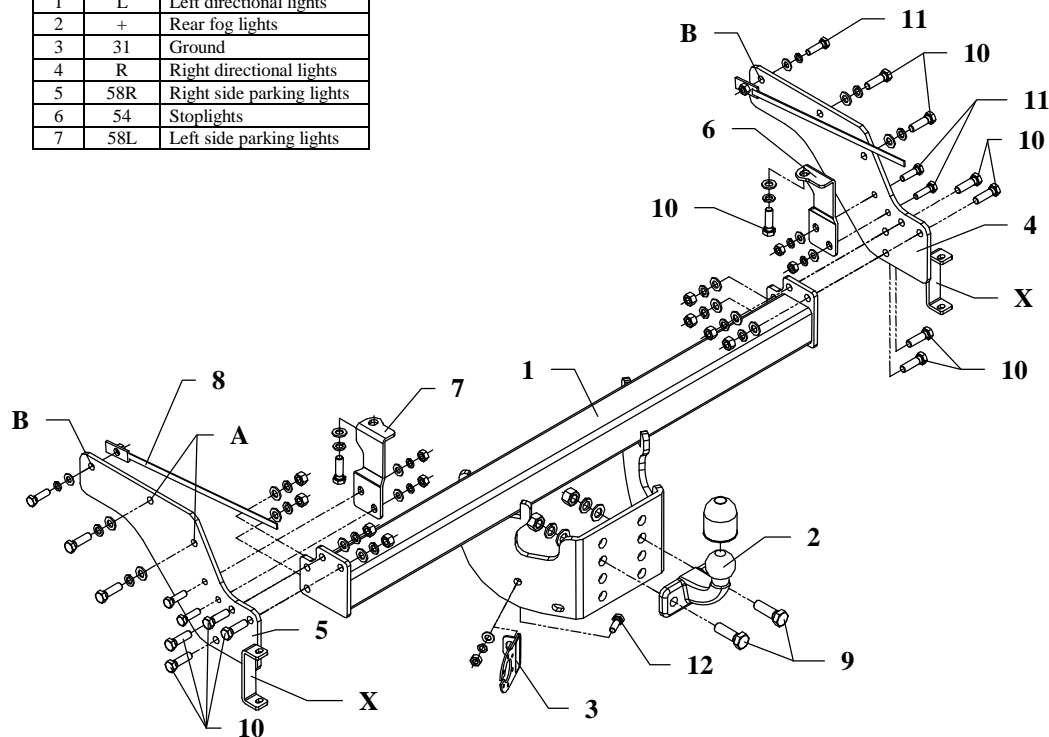

This towing hitch is designed to assembly in following cars:
FORD RANGER, 2/4 WD, produced since 1999, catalogue no. **C41** and is prepared to tow trailers max total weight **2800 kg** and max vertical mass **115 kg**.

From manufacturer

Thank you for buying our product. Their reliability has been confirmed in many tests. Reliability of towing hitch depends also on correct assembly and right operation. For this reasons we kindly ask to read carefully this instruction and apply to hints.

The towing hitch should be install in points described by a car producer.

The instruction of the assembly

1. Disassemble rear bumper with handles (handles will not be used any more).
2. In places after disassembled handles of bumper fix elements of the towing hitch (pos. 4 and 5) through holes A, as shown on the drawing, next through holes B drill using bit $\varnothing 11\text{mm}$ and fix using nuts M10 on the jib (pos. 8).
3. Fix brackets of the towing hitch (pos. 6 and 7) using bolts M10x35mm (pos. 11).
4. Between brackets (pos. 4 and 5) apply the main bar of the towing hitch (pos. 1) and fix using bolts M12x40mm (pos. 10).
5. Fix tow-ball (pos. 2) using bolts M16x50mm (pos. 9) from accessories.
6. Fix socket plate (pos. 3) using bolt M10x30mm (pos. 12).
7. Reassemble bumper to handles X using original bolts.
8. Tighten all bolts according to the torque shown in the table.
9. Connect electric wires of 7-poles socket according to the instruction of the car. (Recommend to make at authorized service station).
10. Complete paint layer damaged during installation.

Torque settings for nuts and bolts (8,8):

M6 - 11 Nm	M8 - 25 Nm	M10 - 50 Nm
M12 - 87 Nm	M14 - 138 Nm	M16 - 210 Nm

NOTE

After install the towing hitch you should get adequate note in registration book (at authorised service station). The car should be equipped with:

- Indicators
- Tow mirrors

After 1000km check all bolts and nuts. The ball of towing hitch must be always kept clear and conserve with a grease.

Towing hitch accessories:

Pos. 1 Main bar PCS.: 1	Pos. 6 Right bracket II PCS.: 1	Pos. 13 Bolt 8,8 B M8x30mm PCS.: 4	Pos. 20 Plain washer ø10.5mm PCS.: 7
	Pos. 7 Left bracket II PCS.: 1	Pos. 14 Nut 8 B M16 PCS.: 2	Pos. 21 Plain washer ø8.5mm PCS.: 4
Pos. 2 Tow ball PCS.: 1	Pos. 8 Jib with the nut PCS.: 2	Pos. 15 Nut 8 B M12 PCS.: 8	Pos. 22 Spring washer ø16.3mm PCS.: 2
Pos. 3 Socket plate PCS.: 1	Pos. 9 Bolt 8,8 B M16x50mm PCS.: 2	Pos. 16 Nut 8 B M10 PCS.: 5	Pos. 23 Spring washer ø12.2mm PCS.: 14
Pos. 4 Right bracket I PCS.: 1	Pos. 10 Bolt 8,8 B M12x40mm PCS.: 14	Pos. 17 Nut 8 B M8 PCS.: 4	Pos. 24 Spring washer ø10.2mm PCS.: 7
Pos. 5 Left bracket I PCS.: 1	Pos. 11 Bolt 8,8 B M10x35mm PCS.: 6	Pos. 18 Plain washer ø17mm PCS.: 2	Pos. 25 Spring washer ø8.2mm PCS.: 4
	Pos. 12 Bolt 8,8 B M10x30mm PCS.: 1	Pos. 19 Plain washer ø13mm PCS.: 14	Pos. 26 Ball cover PCS.: 1



PPUH AUTO-HAK S.J.

Produkcja Zaczepów Kulowych
Henryk & Zbigniew Nejman
76-200 SŁUPSK ul. Słoneczna 16K
tel/fax (059) 8-414-414; 8-414-413
E-mail: office@autohak.com.pl
www.autohak.com.pl

Towing hitch (without electrical set)

Class: **A50-X** Cat. no. **C41**

Designed for:

Manufacturer: **FORD**

Model: **RANGER**

Type: **2/4 WD**

produced since 1999

Technical data:

D-value: 14,21 kN

maximum trailer weight: **2800 kg**

maximum vertical cup mass: **115 kg**

Approval number according to Directive 94/20/EC: e20*94/20*0430*00

Foreword

This towing hitch is designed according to rules of safety traffic regulations. The towing hitch is a safety component and can be install only by qualified personnel. Any alteration or conversion of the towing hitch is prohibited and would lead to cancellation of design certification. Remove insulating compound and underseal from vehicle (if present) in the area of the matting surfaces of the towing hitch. The vehicle manufacturer's specifications regarding trailer mass and max. vertical cup mass are decisive for driving whereat values for the towing hitch cannot be exceeded.

D-value formula:

$$\frac{\text{Max trailer weight [kg]} \times \text{Max vehicle weight [kg]}}{\text{Max trailer weight [kg]} + \text{Max vehicle weight [kg]}} \times \frac{9,81}{1000} = D \text{ [kN]}$$