

FITTING INSTRUCTION

Clamp mark in acc. with		Cables joining
ISO	PN	
1	L	Left directional lights
2	+	Rear fog lights
3	31	Ground
4	R	Right directional lights
5	58R	Right side parking lights
6	54	Stoplights
7	58L	Left side parking lights

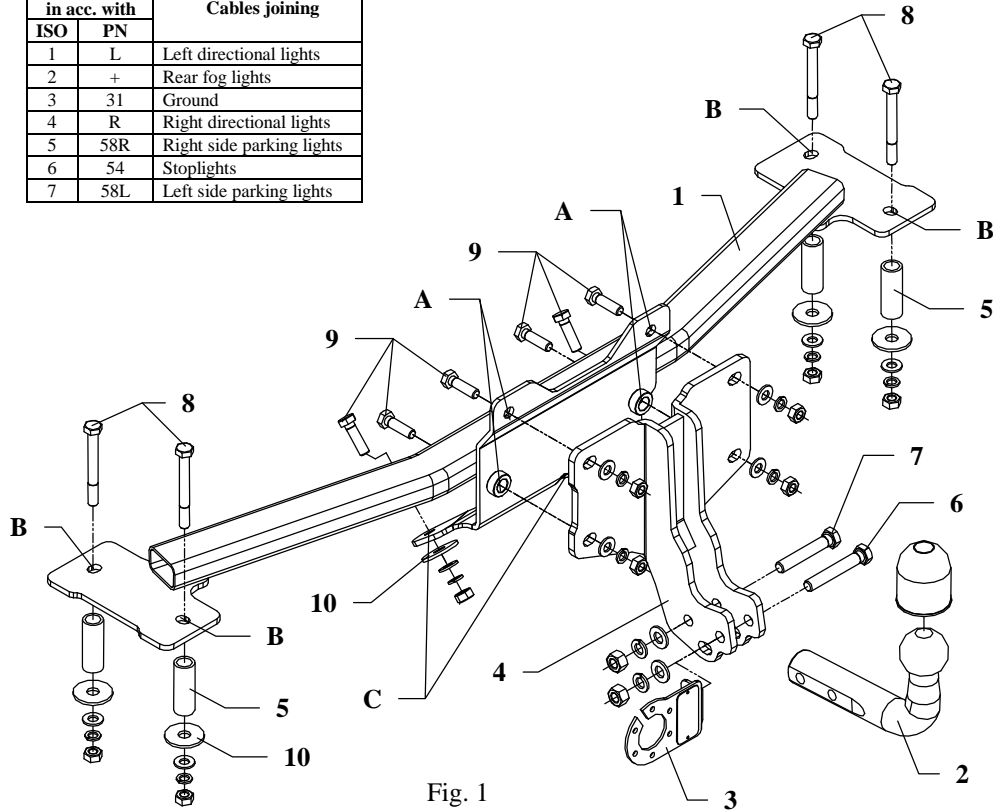

Fig. 1

This towing hitch is designed to assembly in following car:
OPEL KADET „E” 3/5 doors, unscrewed ball, produced since 1984 till 1991, catalogue number **E34** and is prepared to tow trailers max total weight **1200 kg** and max vertical load **50 kg**.

From manufacturer

Thank you for buying our product. Their reliability has been confirmed in many tests. Reliability of towing hitch depends also on correct assembly and right operation. For this reasons we kindly ask to read carefully this instruction and apply to hints.

The towing hitch should be install in points described by a car producer.

Fitting instructions

1. Disassemble the bumper.
2. In factory marked points (in rear part of the car) make four holes A using bit $\varnothing 1\text{mm}$.
3. In the boot (on the left and right side) in factory marked places B make holes $\varnothing 1\text{mm}$ to the chassis members.
4. The main bar of the towing hitch (pos. 1) put into the boot and through already made four holes A fix with ball bracket (pos. 4) using bolts M10x35mm (pos. 9) from accessories.
5. From below the car put distance sleeves L= 58mm (pos. 5), and next through holes B fix using bolts M10x90mm – pos. 8 (use big washers – pos. 10).
6. From the bumper side through holes C drill holes $\varnothing 1\text{mm}$ and fix using bolts M10x35mm (pos. 9) from accessories (use big washers – pos. 10).
7. Install the bumper after cut out of its fragment (see fig. 2).

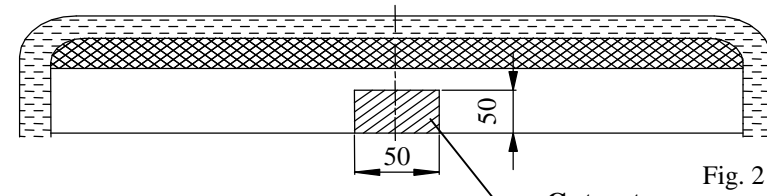

Fig. 2

8. Fix tow ball (pos. 2) using bolt M12x75mm (pos. 6) and M12x70mm (pos. 7). With bolt M12x75mm fix also a socket plate (pos. 3). See figure 1.
9. Fix all bolts according to the torque shown in the table.
10. Connect electric wires according to the instruction of the car. (Recommend to make at authorized service station)
11. Supplement the paint coating damaged during assembly.

Torque settings for nuts and bolts (8,8):

M 8	25 Nm	M 10	55 Nm
M 12	85 Nm	M 14	135 Nm

NOTE

After install the towing hitch you should get adequate registration in registration book (at authorised service station).The car should be equipped with:

- Trafficators
- Tow mirrors

After 1000km check all bolts and nuts. The ball of towing hitch must be always kept clear and conserve with a grease.

Towing hitch accessories:

Pos. 1 Main bar PCS.: 1	Pos. 5 Distance sleeve ø21.3x2.65mm L=58mm PCS.: 4	Pos. 10 Washer ø40xø12x3mm PCS.: 6	Pos. 15 Spring washer ø12mm PCS.: 2
Pos. 2 Tow ball PCS.: 1	Pos. 6 Bolt 8,8 B M12x75mm PCS.: 1	Pos. 11 Nut 8 B M12 PCS.: 2	Pos. 16 Spring washer ø10mm PCS.: 10
Pos. 3 Socket plate PCS.: 1	Pos. 7 Bolt 8,8 B M12x70mm PCS.: 1	Pos. 12 Nut 8 B M10 PCS.: 10	Pos. 17 Ball cover PCS.: 1
Pos. 4 Ball bracket cpl. PCS.: 1	Pos. 8 Bolt 8,8 B M10x90mm PCS.: 4	Pos. 13 Plain washer ø12mm PCS.: 2	
	Pos. 9 Bolt 8,8 B M10x35mm PCS.: 6	Pos. 14 Plain washer ø10mm PCS.: 10	



PPUH AUTO-HAK S.J.

Produkcja Zaczepów Kulowych
Henryk & Zbigniew Nejman
76-200 SŁUPSK ul. Słoneczna 16K
tel/fax (059) 8-414-414; 8-414-413
E-mail: office@autohak.com.pl
www.autohak.com.pl

Towing hitch (without electrical set)

Class: **A50-X** Cat. no. **E34**

Designed for:

Manufacturer: **OPEL**

Model: **KADETT**

Type: **“E”**

produced since 1984 till 1991

Technical data:

D-value: 6,82 kN

maximum trailer weight: **1200 kg**

maximum vertical cup mass: **50 kg**

Approval number acc. to regulations EKG/ONZ 55.01: E20-55R-01 1058

Foreword

This towing hitch is designed according to rules of safety traffic regulations. The towing hitch is a safety component and can be install only by qualified personnel. Any alteration or conversion of the towing hitch is prohibited and would lead to cancellation of design certification. Remove insulating compound and underseal from vehicle (if present) in the area of the matting surfaces of the towing hitch.

The vehicle manufacturer's specifications regarding trailer mass and max. vertical cup mass are decisive for driving whereat values for the towing hitch cannot be exceeded.

D-value formula:

$$\frac{\text{Max trailer weight [kg]} \times \text{Max vehicle weight [kg]}}{\text{Max trailer weight [kg]} + \text{Max vehicle weight [kg]}} \times \frac{9,81}{1000} = D \text{ [kN]}$$