

FITTING INSTRUCTION

Clamp mark in acc. with		Cables joining
ISO	PN	
1	L	Left directional lights
2	+	Rear fog lights
3	31	Ground
4	R	Right directional lights
5	58R	Right side parking lights
6	54	Stoptlights
7	58L	Left side parking lights

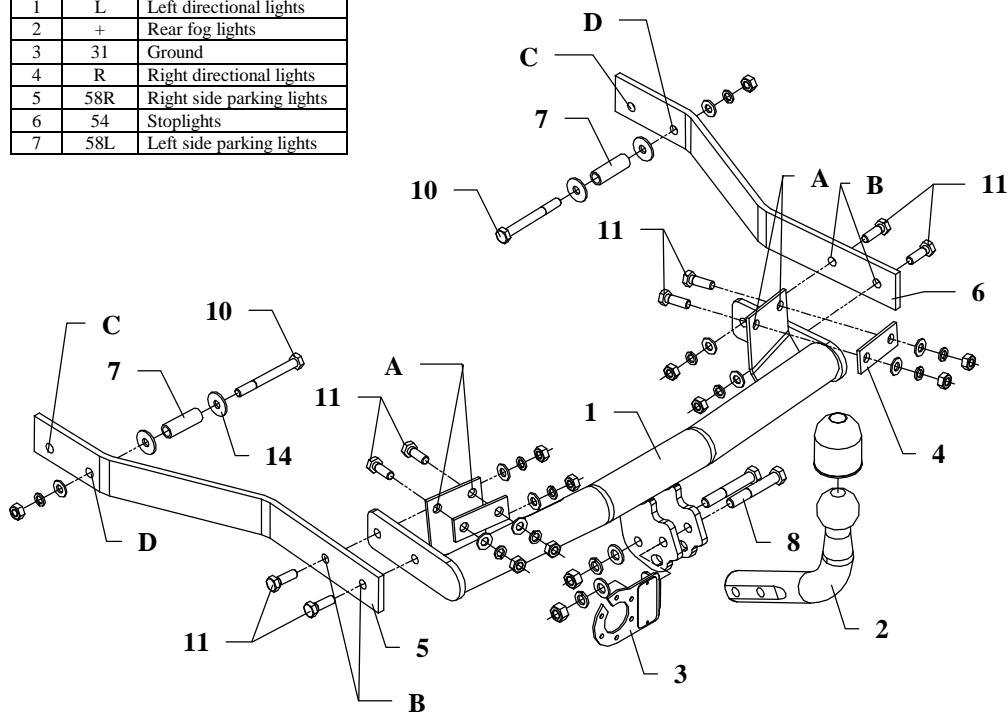

This towing hitch is designed to assembly in following cars: **RENAULT 19, 3/5 doors** and **4 doors**, produced since 05.1992 till 1995, catalogue no. **G05** and is prepared to tow trailers max total weight **1200 kg** and max vertical mass **75 kg**.

From manufacturer

Thank you for buying our product. Their reliability has been confirmed in many tests. Reliability of towing hitch depends also on correct assembly and right operation. For this reasons we kindly ask to read carefully this instruction and apply to hints.

The towing hitch should be install in points described by a car producer.

The instruction of the assembly

1. To install our towing hitch reassemble the bumper and take out the spare wheel, please.
2. Main bar of towing hitch (pos. 1) put below the car and through holes (pos. A), original holes in rear panel and fish-plates (pos. 4) fix to car by M10x30mm bolts (pos. 11) from towing hitch accessories.
3. In elongated holes put distance sleeves (pos. 7) from accessories (per one for left and right side).
4. To mounted bar (pos. 1) through holes (pos. B) fix side brackets (pos. 5 and 6) by bolts M10x30mm (pos. 11).
5. Through holes (see NOTE!) in parts (pos. 5 and 6) and distance sleeves (pos. 7) fix with bolts M10x90mm (pos. 10) from accessories.

NOTE!

- version Renault 19 4 doors - holes pos. C,
 - version Renault 19 3/5 doors - holes pos. D.
6. Fix tow-ball (pos. 2) and socket plate (pos. 3) by bolts M12x75mm (pos. 8) and M12x70mm (pos. 9) from accessories.
 7. Reinstall the bumper and put in the spare wheel.
 8. Tighten all bolts according to the torque shown in the table.
 9. Connect electric wires of 7-pole socket according to the instruction of the car. (Recommend to make at authorized service station)
 10. Complete paint layer damaged during installation.

Torque settings for nuts and bolts (8,8):

M6 - 11 Nm	M 8 - 25 Nm	M 10 - 50 Nm
M 12 - 87 Nm	M 14 - 138 Nm	M16 - 210 Nm











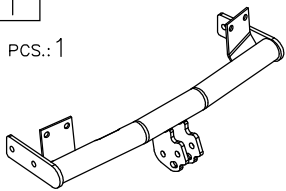
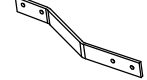

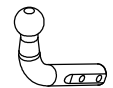
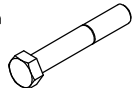

NOTE

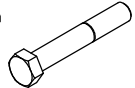
After install the towing hitch you should get adequate note in registration book (at authorised service station). The car should be equipped with:

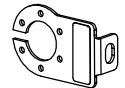
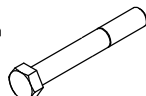
- Indicators
- Tow mirrors

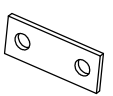
After 1000km check all bolts and nuts. The ball of towing hitch must be always kept clear and conserve with a grease.

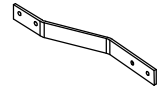
Towing hitch accessories:

Pos. 1 Main bar PCS.: 1	Pos. 6 Right bracket PCS.: 1	Pos. 13 Nut 8 B M10 PCS.: 10
		
	Pos. 7 Distance sleeve ø17.2x2.35mm L=49mm PCS.: 2	Pos. 14 Washer ø30xø10.5x2.5mm PCS.: 4
		
Pos. 2 Tow ball PCS.: 1	Pos. 8 Bolt 8,8 B M12x75mm PCS.: 1	Pos. 15 Plain washer ø13mm PCS.: 2
		
	Pos. 9 Bolt 8,8 B M12x70mm PCS.: 1	Pos. 16 Plain washer ø10.5mm PCS.: 10
		
Pos. 3 Socket plate PCS.: 1	Pos. 10 Bolt 8,8 B M10x90mm PCS.: 2	Pos. 17 Spring washer ø12.2mm PCS.: 2
		
Pos. 4 Fish-plate PCS.: 2	Pos. 11 Bolt 8,8 B M10x30mm PCS.: 8	Pos. 18 Spring washer ø10.2mm PCS.: 10
		
Pos. 5 Left bracket PCS.: 1	Pos. 12 Nut 8 B M12 PCS.: 2	Pos. 19 Ball cover PCS.: 1
		



PPUH AUTO-HAK Sp.J.

Produkcja Zaczepów Kulowych
Henryk & Zbigniew Nejman
76-200 SŁUPSK ul. Słoneczna 16K
tel/fax (059) 8-414-414; 8-414-413
E-mail: office@autohak.com.pl
www.autohak.com.pl

Towing hitch (without electrical set)

Class: **A50-X** Cat. no. **G05**

Designed for:

Manufacturer: **RENAULT**

Model: **19**

Type: **3/5 doors, 4 doors**

produced since 05.1992 till 1995

Technical data:

D-value: 7,1 kN

maximum trailer weight: **1200 kg**

maximum vertical cup mass: **75 kg**

Approval number according to Directive 94/20/EC: e20*94/20*0147*00

Foreword

This towing hitch is designed according to rules of safety traffic regulations. The towing hitch is a safety component and can be install only by qualified personnel. Any alteration or conversion of the towing hitch is prohibited and would lead to cancellation of design certification. Remove insulating compound and underseal from vehicle (if present) in the area of the matting surfaces of the towing hitch. The vehicle manufacturer's specifications regarding trailer mass and max. vertical cup mass are decisive for driving whereat values for the towing hitch cannot be exceeded.

D-value formula:

$$\frac{\text{Max trailer weight [kg]} \times \text{Max vehicle weight [kg]}}{\text{Max trailer weight [kg]} + \text{Max vehicle weight [kg]}} \times \frac{9,81}{1000} = D \text{ [kN]}$$