

FITTING INSTRUCTION

Clamp mark in acc. with		Cables joining
ISO	PN	
1	L	Left directional lights
2	+	Rear fog lights
3	31	Ground
4	R	Right directional lights
5	58R	Right side parking lights
6	54	Stoplights
7	58L	Left side parking lights

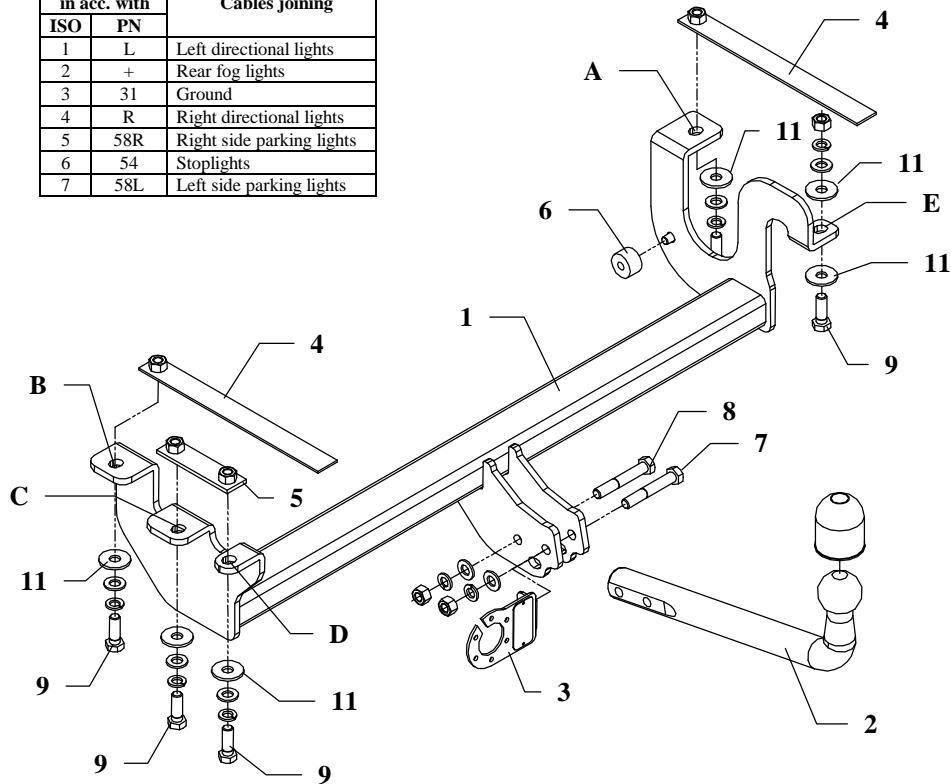

This towbar is designed to assembly in following car:
SUZUKI JIMNY produced since 1998, catalogue number **W16** and is prepared to tow trailers max total weight **1100 kg** and max vertical load **75 kg**.

From manufacturer

Thank you for buying our product. Their reliability has been confirmed in many tests. Reliability of towbar depends also on correct assembly and right operation. For this reasons we kindly ask to read carefully this instruction and apply to hints.

The towbar should be install in points described by a car producer.

The instruction of the assembly

1. Disassemble lower part of bumper.
2. Disassemble original towing eye.
3. Put main bar of the towbar (pos. 1) to chassis members (holes pos. A and B agree to factory made holes) and fix with jibs with nut (pos. 4), jibs slip into chassis members.
4. Through holes (pos. C, D and E) drill holes using bit $\varnothing 13$ mm, and next fix with fish-plate with nuts (pos. 5) using bolts M12x35mm (pos. 9) and big washers (pos. 11), see drawing.
5. Fix tow-ball (pos. 2) and socket plate (pos. 3) using bolts M12x75mm (pos. 7) and M12x70mm (pos. 8) from accessories.
6. Tighten all bolts according to the torque shown in the table.
7. Connect electric wires of 7-pole socket according to the instruction of the car. (Recommended to make at authorized service station)
8. Complete paint layer damaged during installation..

Torque settings for nuts and bolts (8,8):	
M 8 - 25 Nm	M 10 - 55 Nm
M 12 - 85 Nm	M 14 - 135 Nm









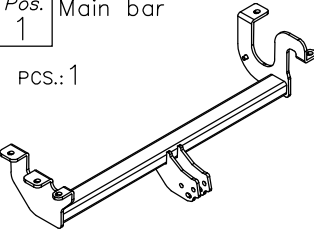
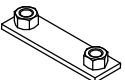

NOTE

After install the towbar you should get adequate note in registration book (at authorised service station).The car should be equipped with:

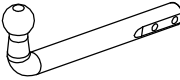
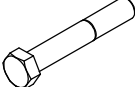
- Indicators
- Tow mirrors

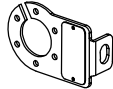
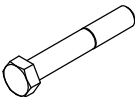
After 1000km check all bolts and nuts. The ball of towbar must be always kept clear and conserve with a grease.

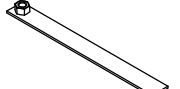
Towbar's accessories:

<p>Pos. 1 Main bar</p>  <p>PCS.: 1</p>	<p>Pos. 5 Flash-plate with nuts</p>  <p>PCS.: 1</p>	<p>Pos. 10 Nut 8 B M12</p>  <p>PCS.: 3</p>
	<p>Pos. 6 Rubber bumper</p>  <p>PCS.: 1</p>	<p>Pos. 11 Washer ø35xø12x4mm</p>  <p>PCS.: 6</p>
<p>Pos. 2 Tow ball</p>  <p>PCS.: 1</p>	<p>Pos. 7 Bolt 8,8 B M12x75mm</p>  <p>PCS.: 1</p>	<p>Pos. 12 Plain washer ø12mm</p>  <p>PCS.: 7</p>
<p>Pos. 3 Socket plate</p>  <p>PCS.: 1</p>	<p>Pos. 8 Bolt 8,8 B M12x70mm</p>  <p>PCS.: 1</p>	<p>Pos. 13 Spring washer ø12mm</p>  <p>PCS.: 7</p>
<p>Pos. 4 Nut on the jib</p>  <p>PCS.: 2</p>	<p>Pos. 9 Bolt 8,8 B M12x35mm</p>  <p>PCS.: 5</p>	<p>Pos. 14 Ball cover</p>  <p>PCS.: 1</p>



PPUH AUTO-HAK S.J.

Produkcja Haków Holowniczych
Henryk & Zbigniew Nejman
76-200 SŁUPSK ul. Słoneczna 16K
tel/fax (059) 8-414-414; 8-414-413
E-mail: office@autohak.com.pl
www.autohak.com.pl

Towing hitch (without electrical set)

Class: **A50-X** Cat. no. **W16**

Designed for:

Manufacturer: **SUZUKI**

Model: **JIMNY**

produced since 1998

Technical data:

maximum D-value: **6,22 kN**

maximum trailer weight: **1100 kg**

maximum vertical cup load: **75 kg**

Approval number acc. to regulations EKG/ONZ 55.01: E20-55R-01 1173

Foreword

This towbar is design according to rules of safety traffic regulations. The towing hitch is a safety component and must be installed only by qualified personnel. Any alteration or conversion to the towing hitch is prohibited and would lead to cancellation of design certification. Remove insulating compound and underseal from vehicle (if present) in the area of the matting surfaces of the towing hitch. The vehicle manufacturer's specifications regarding trailer load and max. vertical cup load are decisive for driving, and values for the towing hitch must not be exceeded.

D-value formula:

$$\frac{\text{Max trailer weight [kg]} \times \text{Max vehicle weight [kg]}}{\text{Max trailer weight [kg]} + \text{Max vehicle weight [kg]}} \times \frac{9,81}{1000} = D \text{ [kN]}$$