

## FITTING INSTRUCTION

Clamp mark in acc. with		Cables joining
ISO	PN	
1	L	Left directional lights
2	+	Rear fog lights
3	31	Ground
4	R	Right directional lights
5	58R	Right side parking lights
6	54	Stoplights
7	58L	Left side parking lights

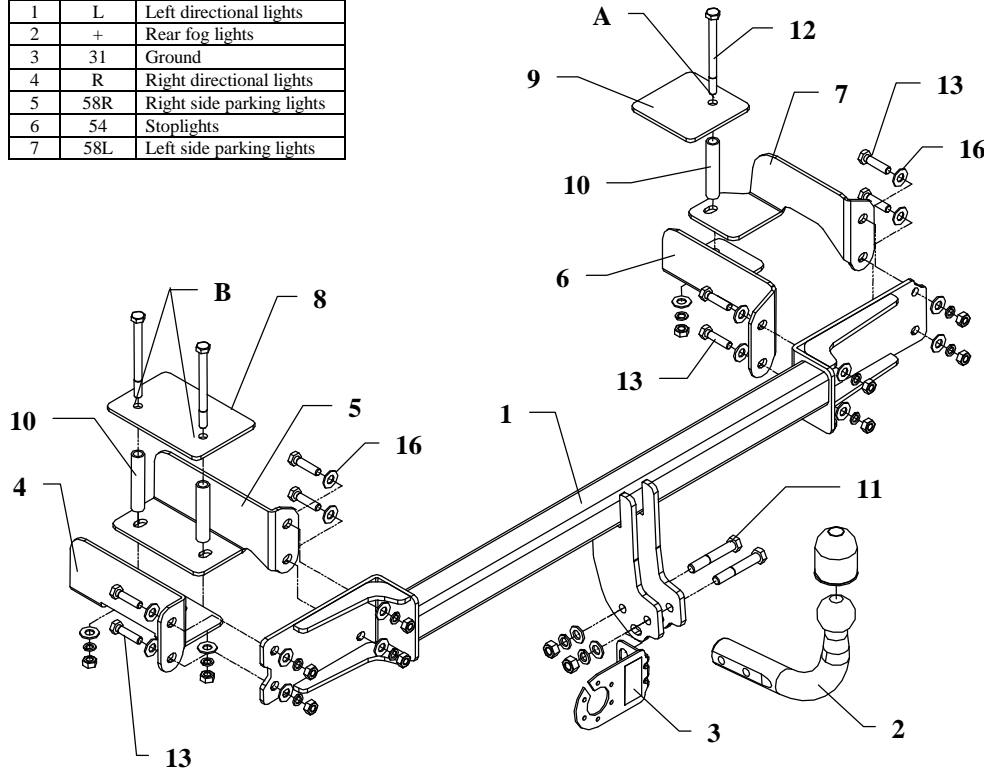

This towing hitch is designed to assembly in following car: **OPEL MERIVA** produced since 2003 till 2010, catalogue number **E42** and is prepared to tow trailers max total weight **1250 kg** and max vertical load **50 kg**.

### *From manufacturer*

Thank you for buying our product. Their reliability has been confirmed in many tests. Reliability of towing hitch depends also on correct assembly and right operation. For this reasons we kindly ask to read carefully this instruction and apply to hints.

*The towing hitch should be install in points described by a car producer.*

## The instruction of the assembly

1. Disassemble the bumper and metal fulfilment (not used any more).
2. Remove side nets and fitted carpet from the trunk.
3. To rear piece put bar of the towing hitch (pos. 1) - towing hitch holes according to original holes, side brackets (pos. 4, 5, 6, 7) put to the chassis members and rear piece of the car. Fix all using bolts M10x40mm (pos. 13). See fig. 1. All elements fix loosely.
4. In the trunk are factory marked points (on the right side one-pos. A and on the left side two-pos. B), drill this points using bit  $\varnothing 17$  mm, and next:
  - put distance sleeves L=85mm (pos. 10),
  - put suitable fish-plates 8 and 9,
  - insert bolts M10x120mm (pos. 12),
  - join with elements 4, 5, 6, 7.
5. Fix all bolts according to the torque shown in the table..
6. Cut out a fragment of the bumper (fig. 2) and mount it.

Fig. 2

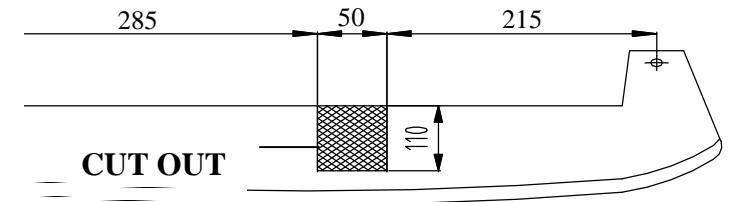

7. Fix tow ball (pos. 2) and socket plate (pos. 3) using bolts M12x75mm (pos. 11) from accessories.
8. Connect electric wires according to the instruction of the car. (Recommend to make at authorized service station)
9. Supplement the paint coating damaged during assembly.

Torque settings for nuts and bolts (8,8):

<b>M 8</b>	25 Nm	<b>M 10</b>	55 Nm
<b>M 12</b>	85 Nm	<b>M 14</b>	135 Nm











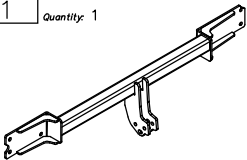
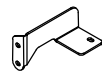
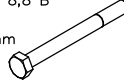

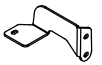



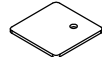

### NOTE

After install the towing hitch you should get adequate registration in registration book (at authorised service station).The car should be equipment with:

- Indicators
- Tow mirrors

After 1000km of exploitation check all bolts and nuts. The ball of towing hitch must be always keep clear and conserve with a grease.

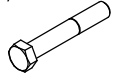
## Towing hitch accessories:

Pos. 1 Name: Main bar Quantity: 1 	Pos. 6 Name: Right bracket A Quantity: 1 	Pos. 12 Name: Bolt 8,8 B Quantity: 3 Dim.: M10x120mm 	Pos. 18 Name: Spring washer Quantity: 2 Dim.: Ø 12,2 mm 
	Pos. 7 Name: Right bracket B Quantity: 1 	Pos. 13 Name: Bolt 8,8 B Quantity: 8 Dim.: M10x40mm 	Pos. 19 Name: Spring washer Quantity: 11 Dim.: Ø 10,2 mm 
Pos. 2 Name: Tow ball Quantity: 1 	Pos. 8 Name: Left fish-plate Quantity: 1 	Pos. 14 Name: Nut 8 B Quantity: 2 Dim.: M12 	Pos. 20 Name: Ball cover Quantity: 1 
Pos. 3 Name: Socket plate Quantity: 1 	Pos. 9 Name: Right fish-plate Quantity: 1 	Pos. 15 Name: Nut 8 B Quantity: 11 Dim.: M10 	
Pos. 4 Name: Left bracket A Quantity: 1 	Pos. 10 Name: Distance sleeve Quantity: 3 Dim.: Ø17,3x2,35mm L=85mm 	Pos. 16 Name: Washer Quantity: 19 Dim.: Ø25xØ12x2mm 	
Pos. 5 Name: Left bracket B Quantity: 1 	Pos. 11 Name: Bolt 8,8 B Quantity: 2 Dim.: M12x75mm 	Pos. 17 Name: Plain washer Quantity: 2 Dim.: Ø 13 mm 	



**PPUH AUTO-HAK S.J.**

Produkcja Zaczepów Kulowych  
Henryk & Zbigniew Nejman  
76-200 SŁUPSK ul. Słoneczna 16K  
tel/fax (059) 8-414-414; 8-414-413  
E-mail: office@autohak.com.pl  
www. autohak.com.pl

## Towing hitch (without electrical set)

Class: **A50-X** Cat. no. **E42**

Designed for:

Manufacturer: **OPEL**

Model: **MERIVA**

produced since 2003 till 2010

Technical data:

**D-value: 7,6 kN**

maximum trailer weight: **1250 kg**

maximum vertical cup load: **50 kg**

Approval number acc. to regulations EKG/ONZ 55.01: **E20-55R-01 1057**

## Foreword

This towing hitch is designed according to rules of safety traffic regulations. The towing hitch is a safety component and can be install only by qualified personnel. Any alteration or conversion of the towing hitch is prohibited and would lead to cancellation of design certification. Remove insulating compound and underseal from vehicle (if present) in the area of the matting surfaces of the towing hitch. The vehicle manufacturer's specifications regarding trailer load and max. vertical cup load are decisive for driving whereat values for the towing hitch cannot be exceeded.

*D-value formula:*

$$\frac{\text{Max trailer weight [kg]} \times \text{Max vehicle weight [kg]}}{\text{Max trailer weight [kg]} + \text{Max vehicle weight [kg]}} \times \frac{9,81}{1000} = D \text{ [kN]}$$