

FITTING INSTRUCTION

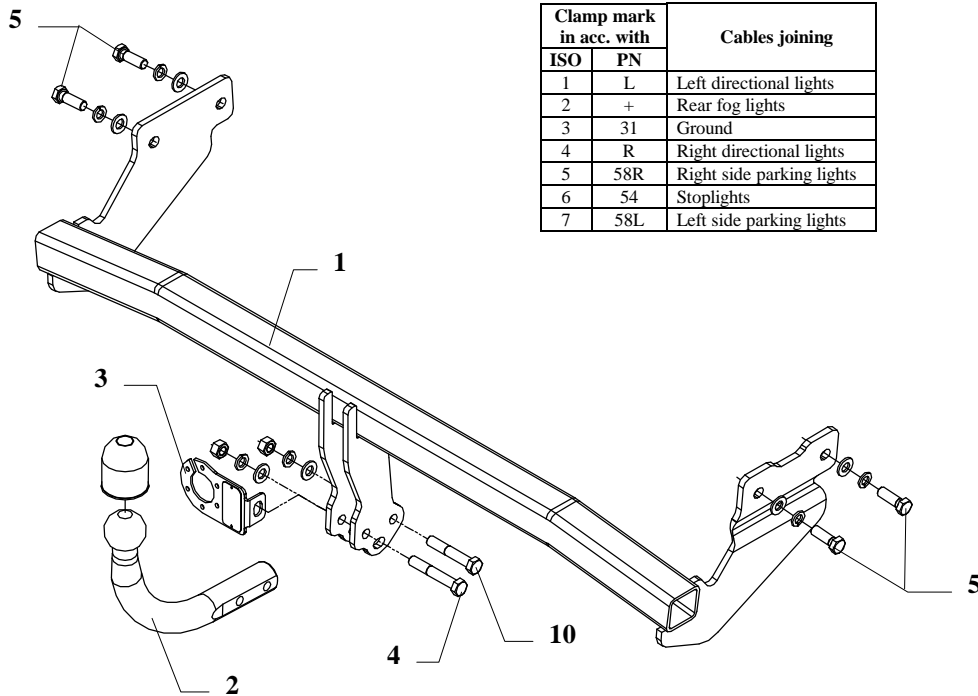

This towing hitch is designed to assembly in following cars: **KIA PICANTO 3/5 door**, produced since 2003, catalogue no. **T46** and is prepared to tow trailers max total weight **700 kg** and max vertical load **28 kg**.

From manufacturer

Thank you for buying our product. Their reliability has been confirmed in many tests. Reliability of towing hitch depends also on correct assembly and right operation. For this reasons we kindly ask to read carefully this instruction and apply to hints.

The towing hitch should be install in points described by a car producer.

The instruction of the assembly

1. Disassemble rear light unit.
2. Disassemble rear bumper and metal reinforcement. Metal reinforcement will be not used any more.
3. Disassemble plastic covers from both sides of the chassis, see fig. 3.
4. Put main bar of the towing hitch (pos. 1) to chassis members in this way, so holes of the towing hitch agree with original holes in chassis members. Twist bolts M12x1,25x35mm (pos. 5).
5. Mount cover elements after cut right element according to figure 3.
6. Reassemble the bumper after cut his fragments according to figure 2.
7. Fix tow ball (pos. 2) using bolt M12x75mm (pos. 4) and M12x70mm (pos. 10). With bolt M12x75mm fix also a socket plate (pos. 3). See figure 1.
8. Tighten all bolts according to the torque shown in the table.
9. Connect electric wires of 7-pole socket according to the instruction of the car. (Recommend to make at authorized service station)
10. Complete paint layer damaged during installation.

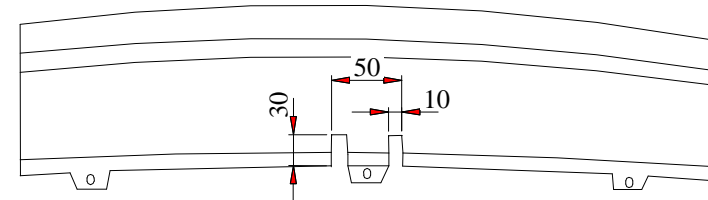

Fig. 2. Bumper cut out

Attention!
Cut only right cover.

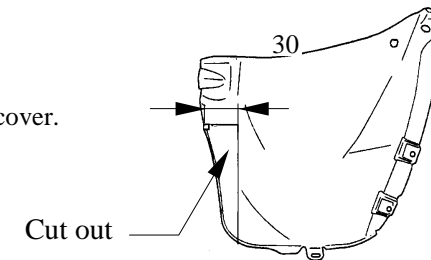

Fig. 3. Right side cover – cut out.







NOTE

After install the towing hitch you should get adequate note in registration book (at authorised service station).The car should be equipped with:

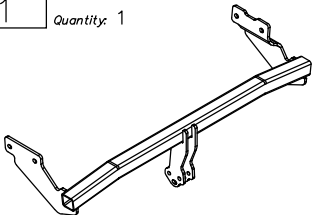
- Indicators
- Tow mirrors

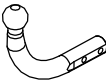
After 1000km of exploitation check all bolts and nuts. The ball of towing hitch must be always kept clear and conserve with a grease.

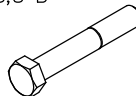
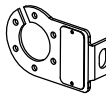
Towing hitch accessories:

Pos. 1	Name: Main bar Quantity: 1	Pos. 4	Name: Bolt 8,8 B Quantity: 1 Dim.: M12x75mm	Pos. 8	Name: Spring washer Quantity: 6 Dim.: \varnothing 12,2 mm
		Pos. 5	Name: Bolt 8,8 B Quantity: 4 Dim.: M12x1,25x35mm	Pos. 9	Name: Ball cover Quantity: 1
					
Pos. 2	Name: Tow-ball Quantity: 1	Pos. 6	Name: Nut 8 B Quantity: 2 Dim.: M12	Pos. 10	Name: Bolt 8,8 B Quantity: 1 Dim.: M12x70mm
					
Pos. 3	Name: Socket plate Quantity: 1	Pos. 7	Name: Plain washer Quantity: 6 Dim.: \varnothing 13 mm		
					

Torque settings for nuts and bolts (8,8):

M8	25 Nm	M10	55 Nm
M12	85 Nm	M14	135 Nm



PPUH AUTO-HAK S.J.

Produkcja Zaczepów Kulowych
Henryk & Zbigniew Nejman
76-200 SŁUPSK ul. Słoneczna 16K
tel/fax (059) 8-414-414; 8-414-413
E-mail: office@autohak.com.pl
www. autohak.com.pl

Towing hitch (without electrical set)

Class: **A50-X** Cat. no. **T46**

Designed for:

Manufacturer: **KIA**

Model: **PICANTO**

Type: **3/5 door**

produced since 2003

Technical data:

D-value: 5,0 kN

maximum trailer weight: **700 kg**

maximum vertical cup load: **28 kg**

Approval number according to Directive 94/20/EC: **e20*94/20*0212*00**

Foreword

This towing hitch is designed according to rules of safety traffic regulations. The towing hitch is a safety component and must be installed only by qualified personnel. Any alteration or conversion to the towing hitch is prohibited and would lead to cancellation of design certification. Remove insulating compound and underseal from vehicle (if present) in the area of the matting surfaces of the towing hitch.

The vehicle manufacturer's specifications regarding trailer load and max. vertical cup load are decisive for driving, and values for the towing hitch cannot be exceeded.

D-value formula:

$$\frac{\text{Max trailer weight [kg]} \times \text{Max vehicle weight [kg]}}{\text{Max trailer weight [kg]} + \text{Max vehicle weight [kg]}} \times \frac{9,81}{1000} = D \text{ [kN]}$$